

Phone: 410-760-1446  
 Fax: 410-760-7564  
 Email: Sales@SFI.Zone



190 Penrod Ct  
 Suite G  
 Glen Burnie, MD 21061

# Curb

Style CFO-2

\* Company \_\_\_\_\_ Deliver to Company \_\_\_\_\_  
 \* Contact Name \_\_\_\_\_ Deliver to Address \_\_\_\_\_  
 \* Contact Number \_\_\_\_\_  
 Contact Email \_\_\_\_\_ Site Contact 1 Name \_\_\_\_\_ Number \_\_\_\_\_  
 P.O. Number/JobName \_\_\_\_\_ Site Contact 2 Name \_\_\_\_\_ Number \_\_\_\_\_  
 Date Required \_\_\_\_\_ Delivery Day/s &Time/s \_\_\_\_\_

\* REQUIRED

### Curb Material

- Galvanized
- Aluminum
- Stainless Steel

### Options

- Pressure Treated Nailer

### Features

UNITIZED CONSTRUCTION  
 CONTINUOUS WELDED CORNER SEAMS  
 BUILT-IN CANT WITH MITERED CORNERS

### Material Guage

- 18 guage
- 16 guage
- 14 guage
- 12 guage
- 10 guage

### Special Instructions

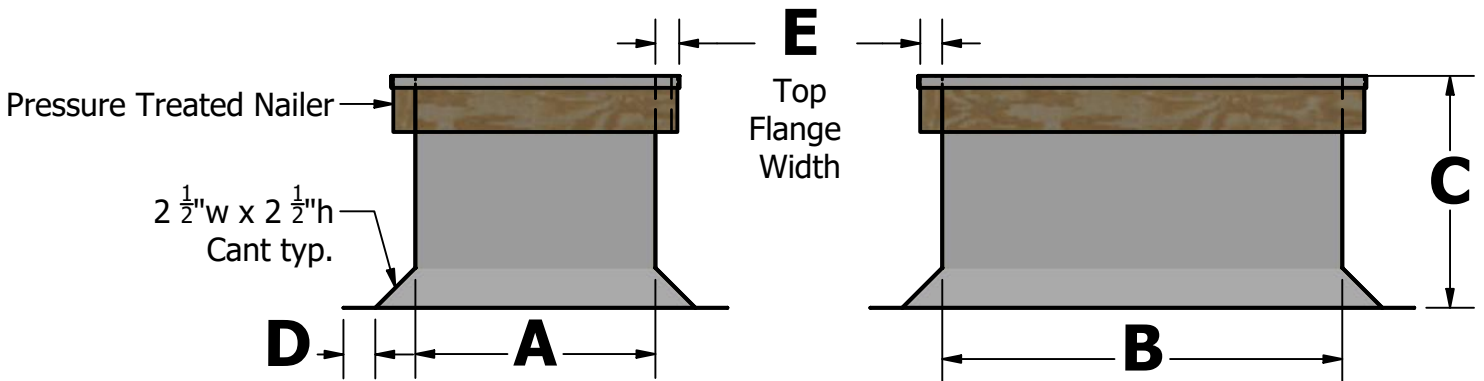
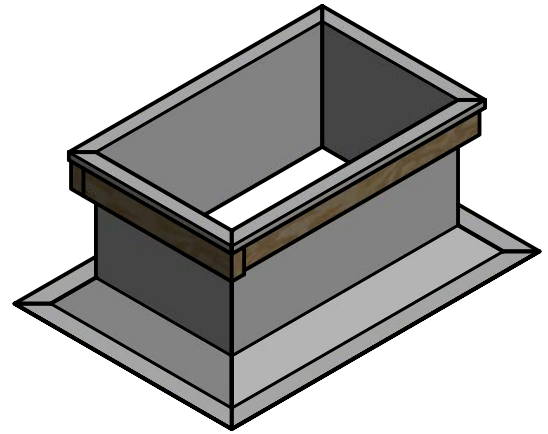

<b>QTY</b>	<b>A</b>	<b>B</b>	<b>C</b>	<b>D</b>	<b>E</b>	<b>Tag</b>
	OD	OD	total Height	Flange Width	Top Flange Width	