

Phone: 410-760-1446
 Fax: 410-760-7564
 Email: Sales@SFI.Zone



190 Penrod Ct
 Suite G
 Glen Burnie, MD 21061

Curb

Style CFO-4

* Company _____ Deliver to Company _____
 * Contact Name _____ Deliver to Address _____
 * Contact Number _____
 Contact Email _____ Site Contact 1 Name _____ Number _____
 P.O. Number/JobName _____ Site Contact 2 Name _____ Number _____
 Date Required _____ Delivery Day/s &Time/s _____

* REQUIRED

Curb Material

- Galvanized
- Aluminum
- Stainless Steel

Options

- Pressure treated Nailer

Features

UNITIZED CONSTRUCTION
 CONTINUOUS WELDED CORNER SEAMS

Material Guage

- 18 guage
- 16 guage
- 14 guage
- 12 guage
- 10 guage

Special Instructions

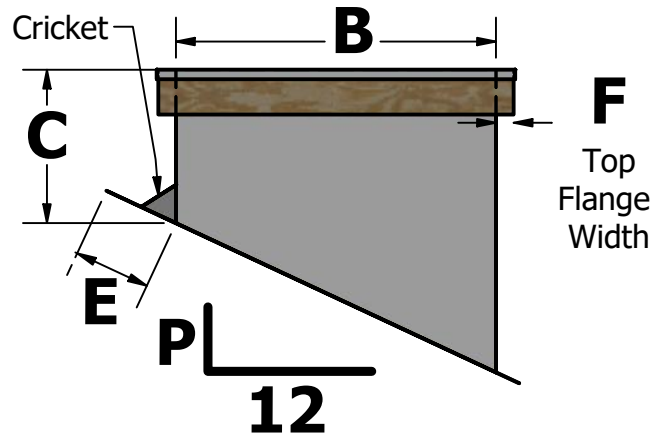
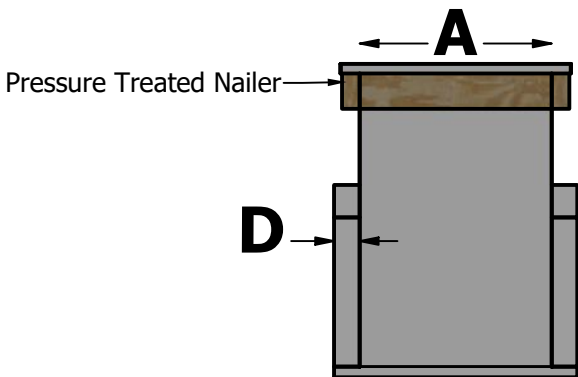
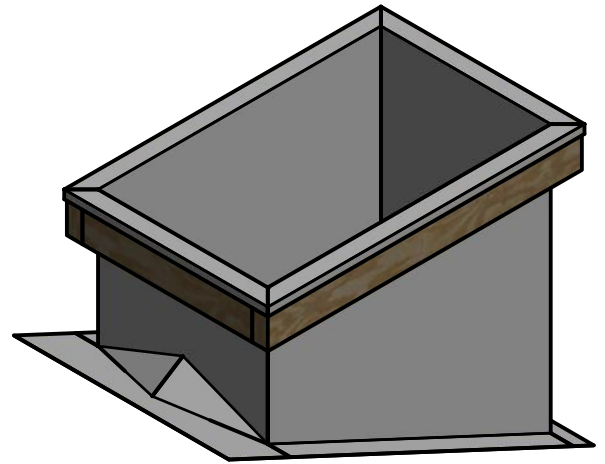

QTY	A	B	C	D	E	F	P	Tag
	OD	OD	Total	Flange Width	High Side	Top Flange	Pitch	
	(ID=OD-3")	(ID=OD-3")	Height	3 Sides	Flange Width	Width		